

# IN HOUSE TESTING BENCH LABORATORY OF AIR HANDLING UNIT FOR AIR MEASURING AND PRESSURE LEAKAGE TEST

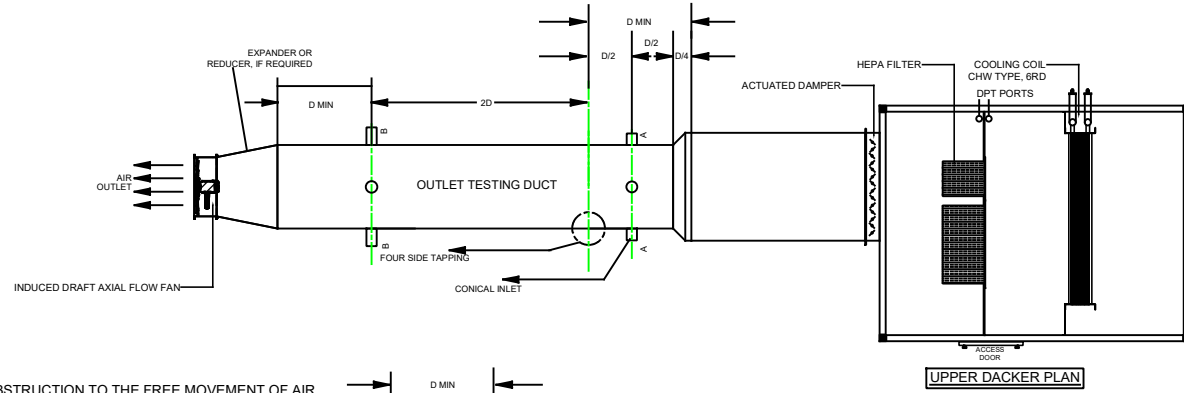

UPPER DACKER PLAN

**NO EXTERNAL OBSTRUCTION TO THE FREE MOVEMENT OF AIR ENTERING THE INLET IS PERMITTED WITHIN THIS REGION. THERE MUST BE NO-EXTRANEIOUS AIR CURRENTS IN THE VICINITY OF THE INLET**

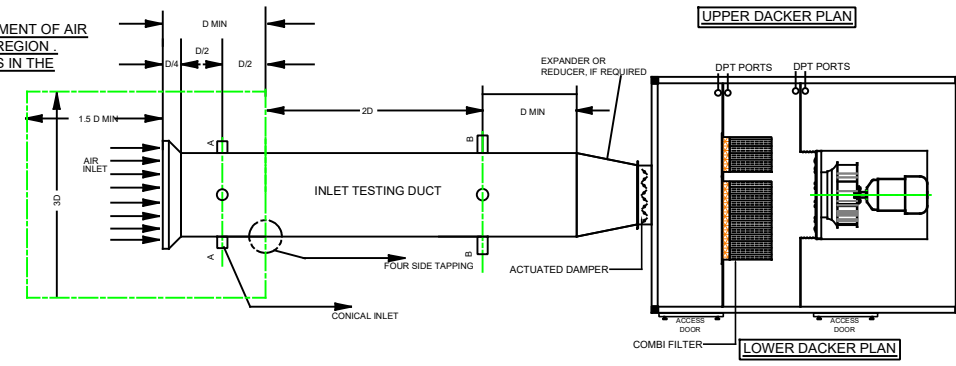

LOWER DACKER PLAN

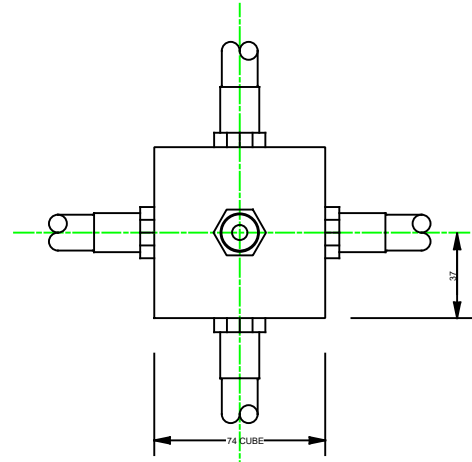

METHOD OF CONNECTION FOR FOUR SIDE TAPPING TO TEST DUCT AND CONNECTION TO MANOMETER FOR INDUCTION OF AVERAGE SIZE THROUGH ONE BLOCK

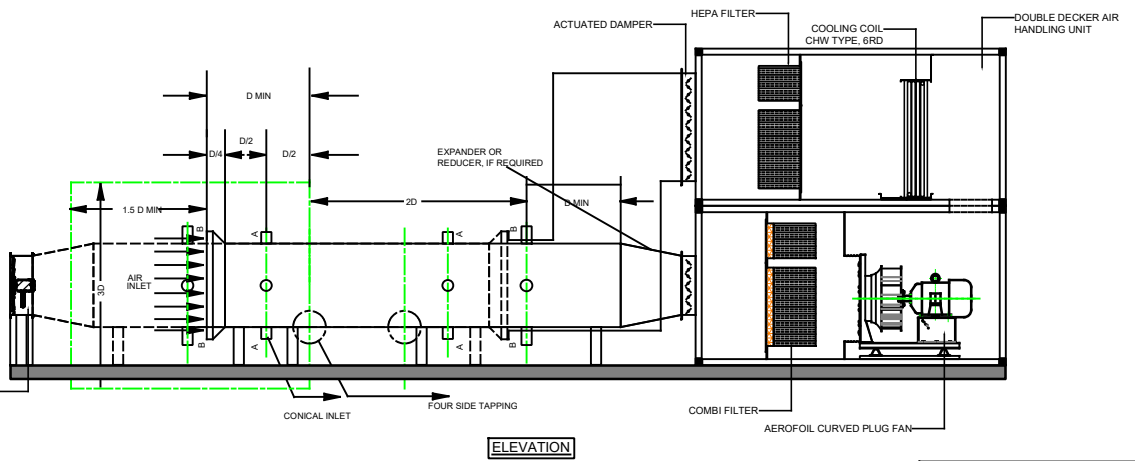
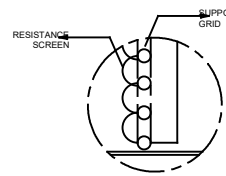

ELEVATION

DO NOT SCALE, ASK IF IN DOUBT

CAD REF. : 1051/07

This drawing and its contents are the property of "AC HUMIDIN AIR SYSTEMS PVT LTD" and no use or disclosure thereof shall be made without its written consent

CLIENT :	KINDLY TICK THE COMPONENTS WHILE FACING THE DRAWING FROM FILTER SIDE:		
CONSULTANT :	1) MOTOR LOCATION - <input type="checkbox"/> R/H <input type="checkbox"/> L/H	<input type="checkbox"/> R/H <input type="checkbox"/> L/H	
PROJECT :	2) COIL CONNECTING - <input type="checkbox"/> R/H <input type="checkbox"/> L/H	<input type="checkbox"/> R/H <input type="checkbox"/> L/H	
	3) DELIVERY MODE - <input type="checkbox"/> ASSEMBLE <input type="checkbox"/> 3RD	<input type="checkbox"/> ASSEMBLE <input type="checkbox"/> 3RD	

REV.	DATE	REVISION RECORD
TITLE :		

DWG. NO. :	REV. :	SHEET :
ALL DIMENSIONS ARE IN mm		
SCALE :	DRAWN BY :	DATE :

DRAWN BY :	DATE :	CHKD. BY :